

Whirlpool CORPORATION





The 15 original employees of Whirlpool



E. & L. C. UPTON.
 POWER TRANSMITTING DEVICE.
 APPLICATION FILED JAN. 17, 1911.
 1,106,903. Patented Aug. 11, 1914.
 6 SHEETS—SHEET 1.

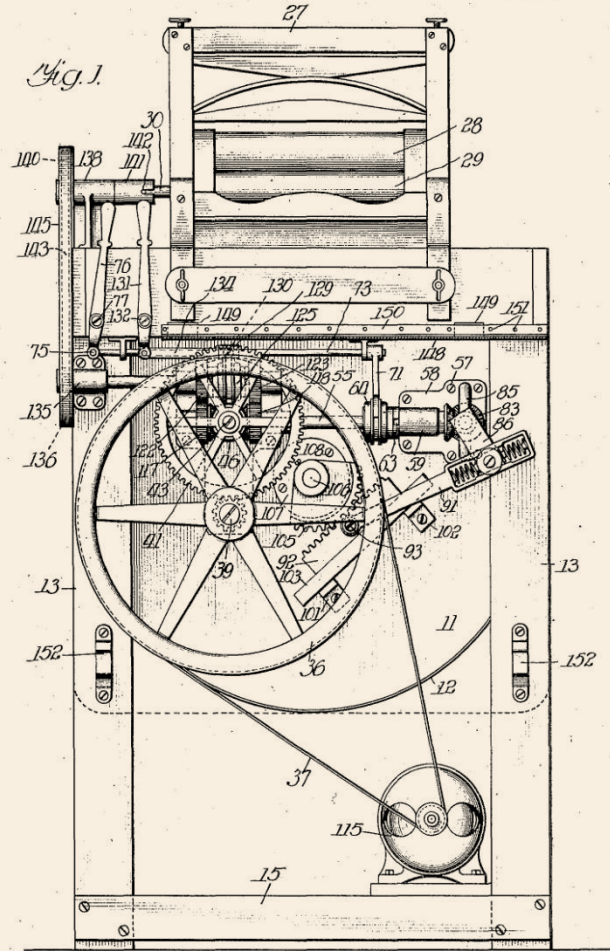

Witnesses: _____ Inventors: _____

Humble beginnings





2007-2013

- Global Financial Crisis
- U.S./Europe Recession
- Volatile Global Marketplace



1911-1948

- Manufacturing
- One Product
- One Customer

1948-1970



- Product Expansion to Full-line
- Whirlpool Brand

Whirlpool



1911-2013

2000-2007

- Innovation
- Maytag

1970-1980



- U.S. Trade Expansion
- #1 U.S.



1990-2000

- Globalization: Europe, Latin America, Asia
- #1 Globally

1980-1990

- Multi-Brand: Whirlpool, KitchenAid, Roper, Estate
- #1 N. America



Whirlpool
HOME APPLIANCES
KitchenAid

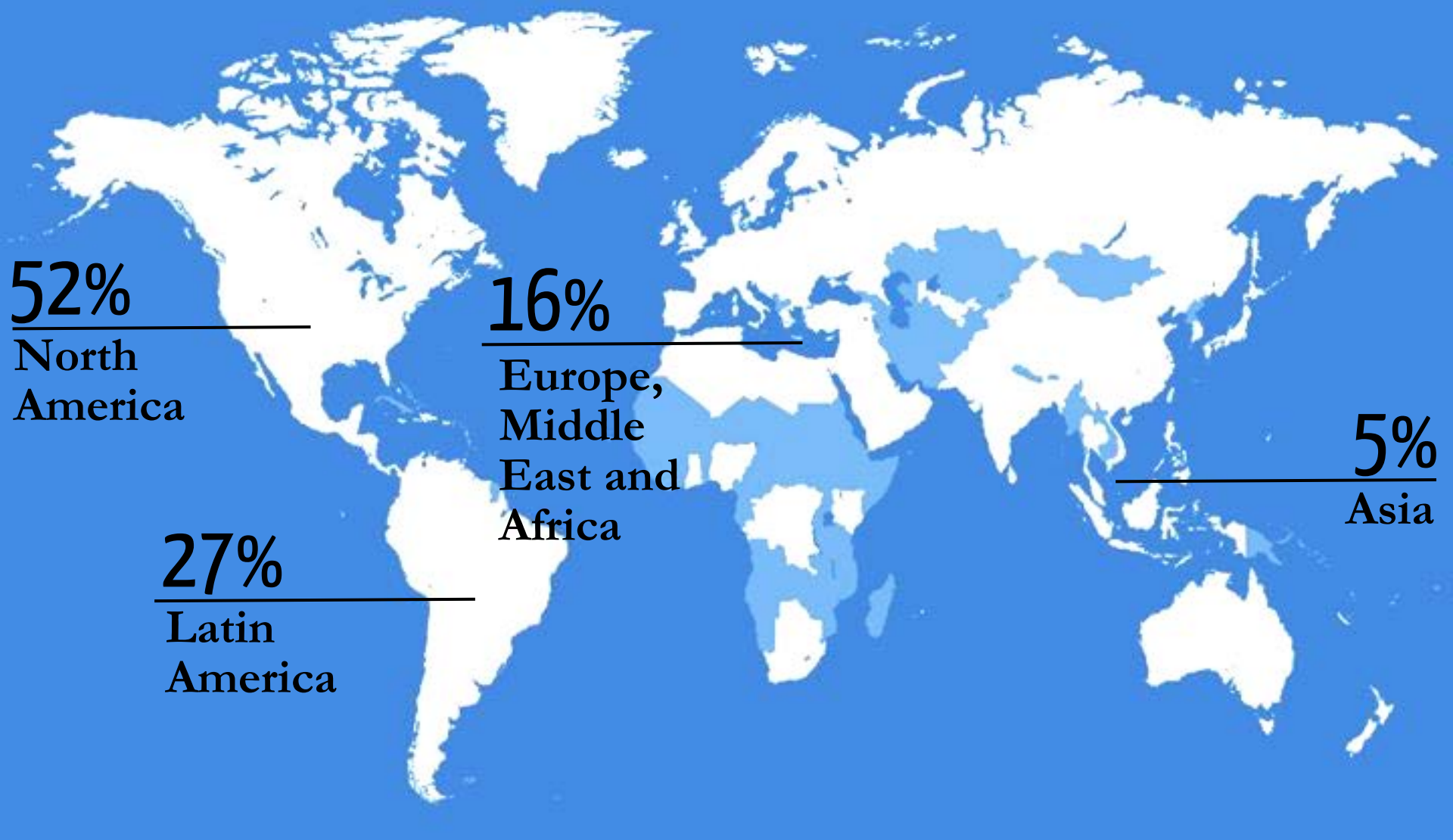

U.S.
8/10 homes
97 million homes

Globally -52m/year
1.7 appliances/sec



1988

10% bigger
53% more efficient
30% more features
13% less cost



2013

Bigger, better and more efficient





Appliances have become an integral part of our homes



Helping you do what you need to do...



Making the most of moments that matter





believe



bold



fast



consumer



Shifting our culture



From a dated, low-cost alternative...





...to modern and delightful



From utilitarian machines...



...to a new era of iconic design



From thinking inside the box...





...to earning trust & creating demand



WHERE MOMENTS MATTER™

Connect with us

 @whirlpoolcorp #whatmatters

www.linkedin.com/company/whirlpool-corporation